

LTR.	REVISIONS	DATE	INT.
△	UPDATED .080 [2.0] TO .090 [2.3]	3-8-17	RAS

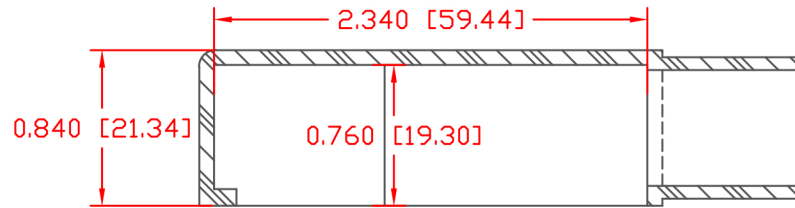
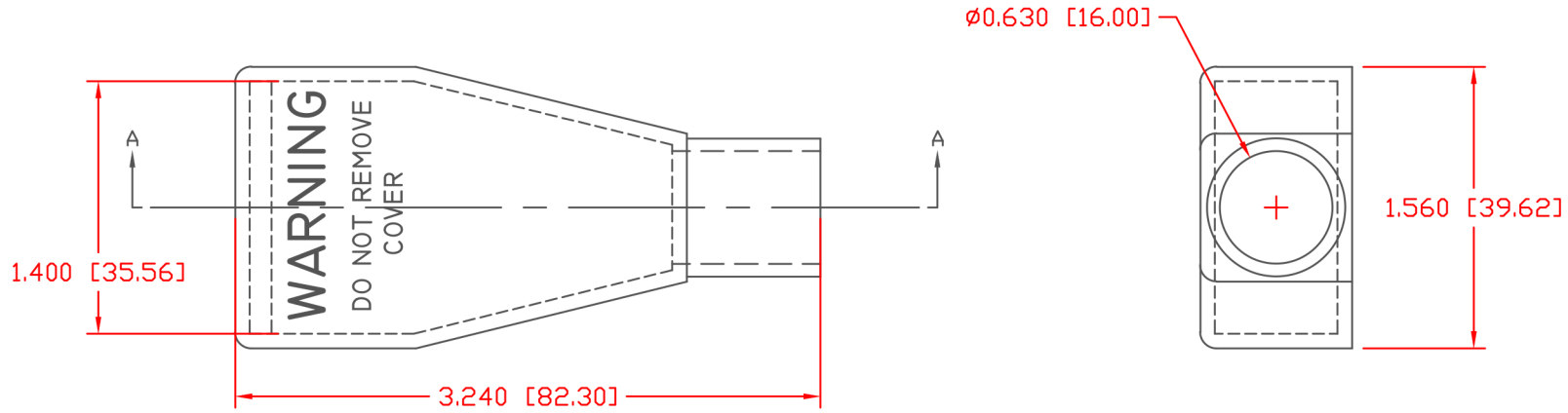

SECTION A-A
 TYP. WALL THICKNESS = .090" [2.3]
 TYP. RADIUS = .090" [2.3]

ALL DIMENSIONS GIVEN AS: In [mm]
 MOLDED PARTS: ±.030" [±0.8mm]

MATERIAL:	PVC
VENDOR PART NO:	9812-65-BLACK
SHORE DUROMETER:	"A" 10 SEC. 65
SPECIFIC GRAVITY:	1.34
ULT. ELONGATION %:	400
MELTING TEMP:	315-335 F [157-168 C]
BRITTLE TEMP:	-54 F [-48 C]
TENSILE STRENGTH PSI:	1550 PSI
DIELECTRIC STRENGTH, V./mil:	453
U.L. RATING:	V2

DO NOT SCALE



REF:	DATE:	DRN BY: JC	WEIGHT:
CUSTOMER DIMS	03-27-98	CHK'D BY: JC	.037 LBS [16.7 g]
TITLE: BATTERY CABLE BOOT			
MATERIAL: PVC			PART NO. 670149
COLOR: BLACK	DRG CLASS	REV A	